

HUFFY[®]SPORTS

Table-Top Basketball Game

Owners Manual

Customer Service Center
• N53 W24700 South Corporate Circle • Sussex, WI 53089 • U.S.A.

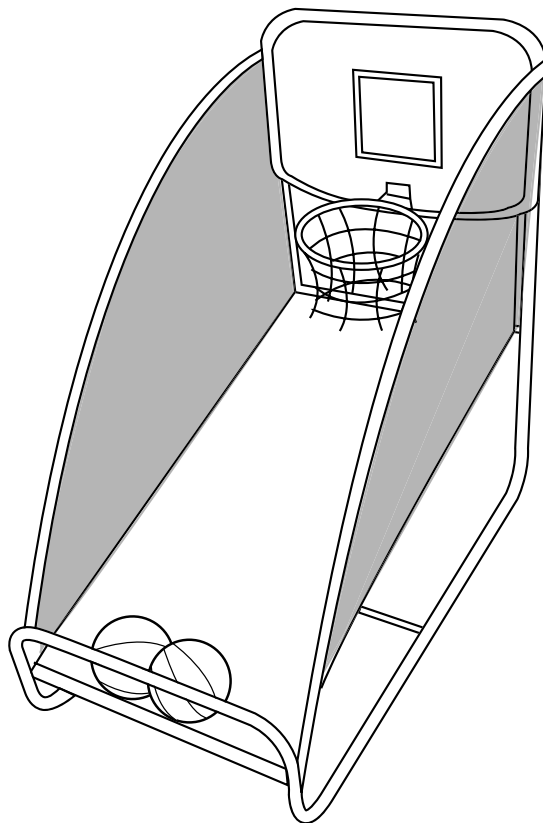

! WARNING !

NOT SUITABLE FOR CHILDREN
UNDER THREE YEARS OF AGE
DUE TO SMALL PARTS/CHOKING
HAZARD.



! WARNING

Read and understand
operator's manual before
using this unit.

Failure to follow operating
instructions could result
in injury or damage to
property.

REQUIRED TOOLS AND MATERIALS:

- Phillips Head Screwdriver

Toll-Free Customer Service Number for U.S: **1-800-558-5234**,

For Canada: **1-800-284-8339**,



For Europe: **00 800 555 85234** (Sweden: **009 555 85234**),

For Australia: **1-800-333 061**

Internet Address: <http://www.huffysports.com>

	Questions or Missing Parts?
	DON'T go back to store!
	Call TOLL-FREE Customer Service Number listed on the front page!

IMPORTANT!
Remove all contents from boxes.

	SAFETY INSTRUCTIONS	
<p>FAILURE TO FOLLOW THESE SAFETY INSTRUCTIONS MAY RESULT IN SERIOUS INJURY, PROPERTY DAMAGE AND WILL VOID WARRANTY.</p> <p><i>Owner must ensure that all players know and follow these rules for safe operation of the system.</i></p> <p>To ensure safety, do not attempt to assemble this system without following the instructions carefully. Proper and complete assembly, use and supervision is essential for proper operation and to reduce the risk of accident or injury. A high probability of serious injury exists if this system is not installed, maintained, and operated properly.</p>		
<ul style="list-style-type: none">• Seat the pole sections properly (if applicable). Failure to do so could allow the pole sections to separate during play and/or during transport of the system.• Climate, corrosion or misuse could result in system failure.• If technical assistance is required, contact Huffy Sports.		
<p><i>Most injuries are caused by misuse and/or not following instructions. Use caution when using this unit.</i></p>		

Get to know the basic parts of your basketball system.....

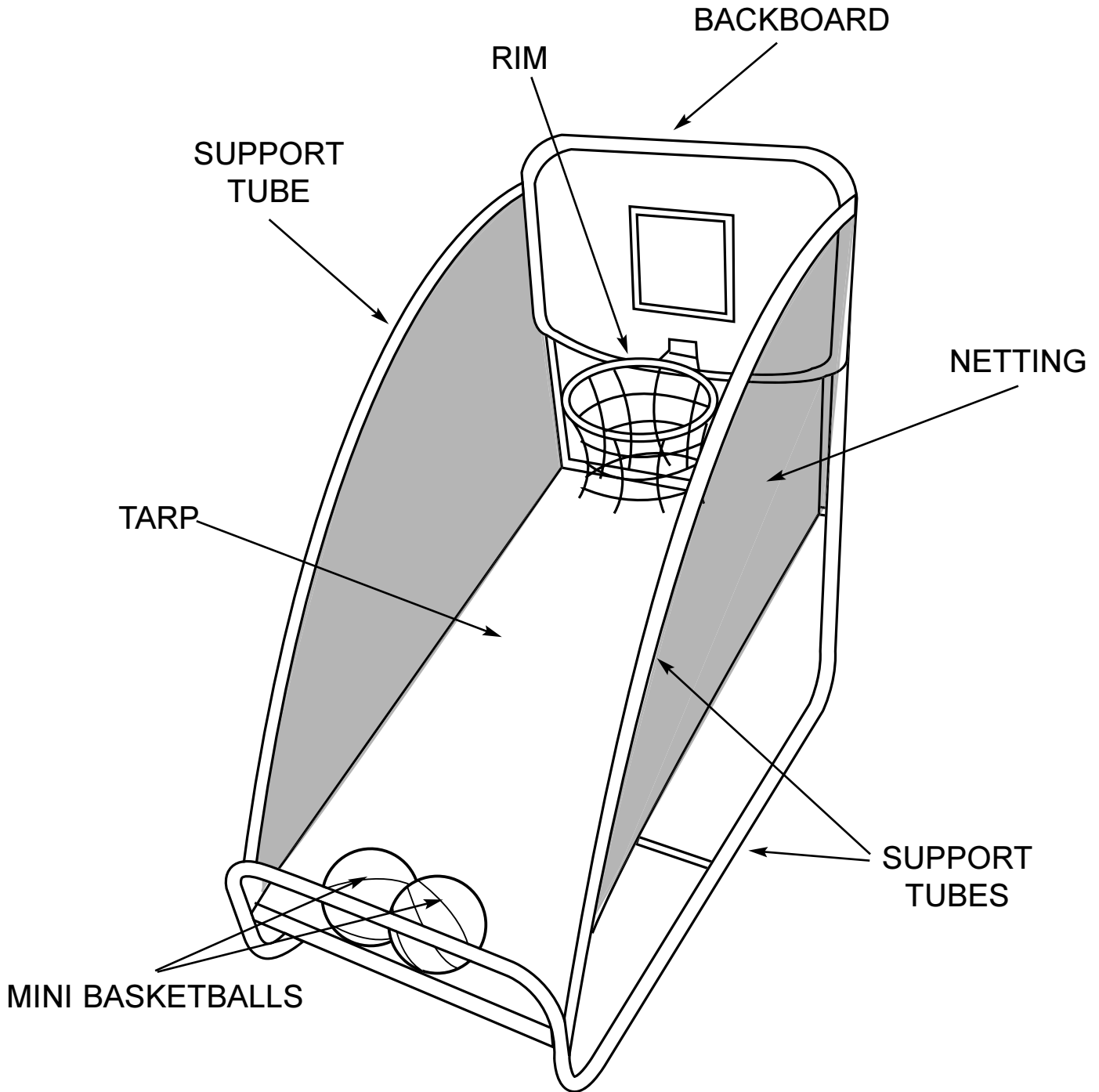

PARTS LIST AND IDENTIFIER

Item	Qty	Part No	Description	Item	Qty	Part No	Description
1	2	202250	Support Pipe, Curved	11	1	202260	Rim Bracket
2	2	202251	Support Pipe, Curved	12	2	202261	Adapter, White, Plastic
3	3	202252	Threaded Stabilizer Pipe, Straight	13	2	202262	Washer
4	4	202253	Support Pipe, White, Plastic	14	2	202263	Shim Bracket, Threaded
5	2	202254	Support Pipe, Straight	15	2	202264	Wing Nut, Plastic
6	1	202255	Upper U-Pipe	16	2	202265	Screw, 1-3/4"
7	1	202256	Lower U-Pipe, Angled Connectors	17	6	202266	Screw, 1-3/8"
8	1	202257	Net	18	4	202267	Screw, 1/2"
9	1	202258	Rim	19	1	202268	Backboard
10	1	202259	Tarp	20	2	202269	Mini Basketball
				21	2	202298	Board Bracket with Hook

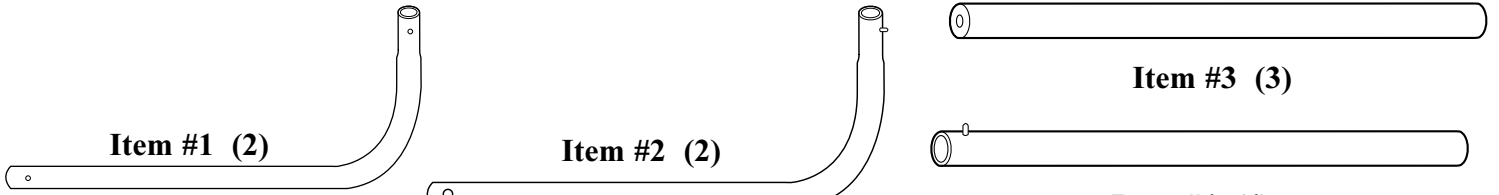

Item #1 (2)

Item #2 (2)

Item #3 (3)

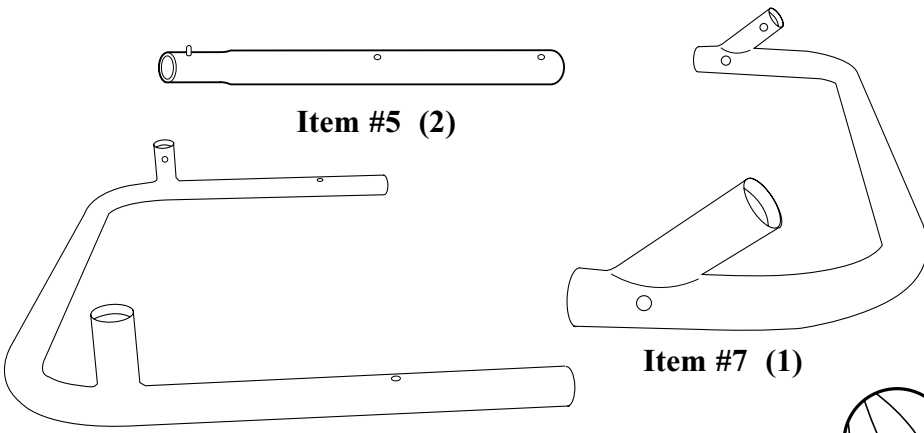

Item #5 (2)

Item #6 (1)

Item #7 (1)

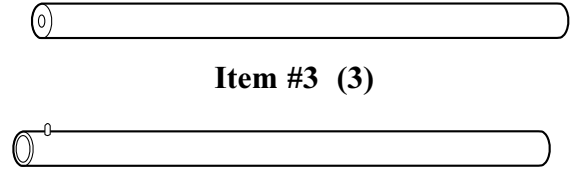

Item #4 (4)

Item #8 (1)

Item #9 (1)

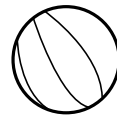

Item #20 (2)

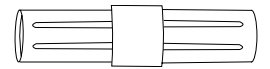

Item #12 (2)

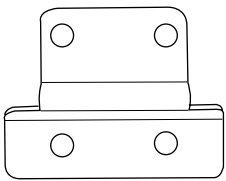

Item #11 (1)

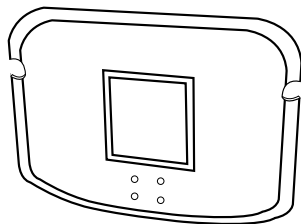

Item #19 (1)

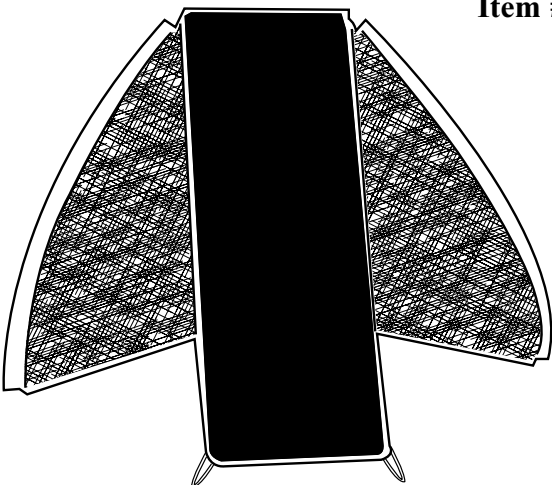

Item #10 (1)

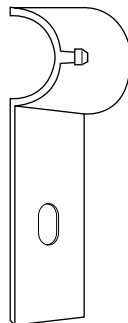

Item #21 (1)

HARDWARE ID (ACTUAL SIZE)

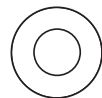

Item #13 (2)

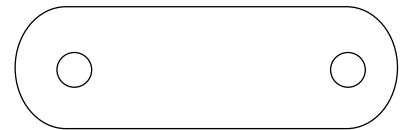

Item #14 (2)

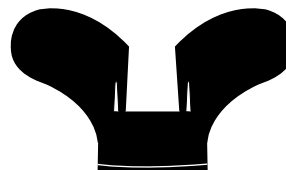

Item #15 (2)



Item #16 (2)



Item #17 (6)

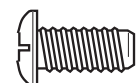

Item #18 (4)

SECTION A: ASSEMBLE THE STAND AND TARP

TOOLS REQUIRED FOR THIS SECTION

Phillips-Head Screwdriver



HARDWARE USED IN THIS SECTION (actual size)



Item #17 (6)

1. Attach lower U-pipe (7) to curved support pipes (1).

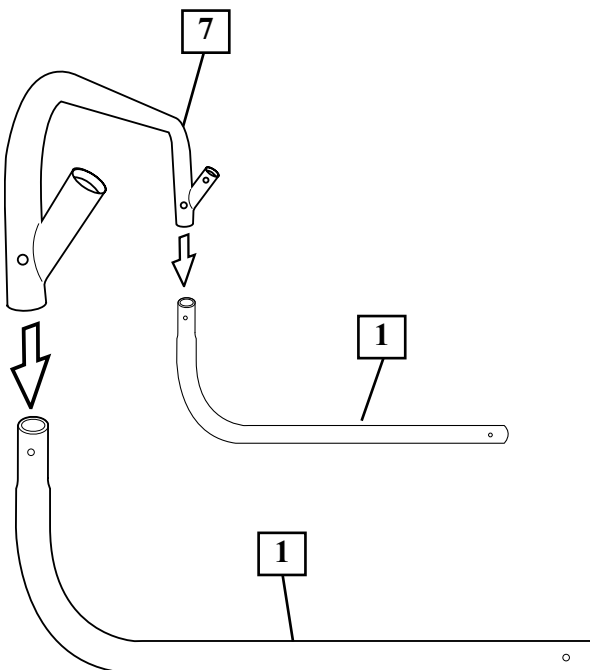

2. Slide sleeve of the tarp (10) over stabilizer pipe (3) and secure by connecting stabilizer pipe (3) to lower U-pipe with screws (17).

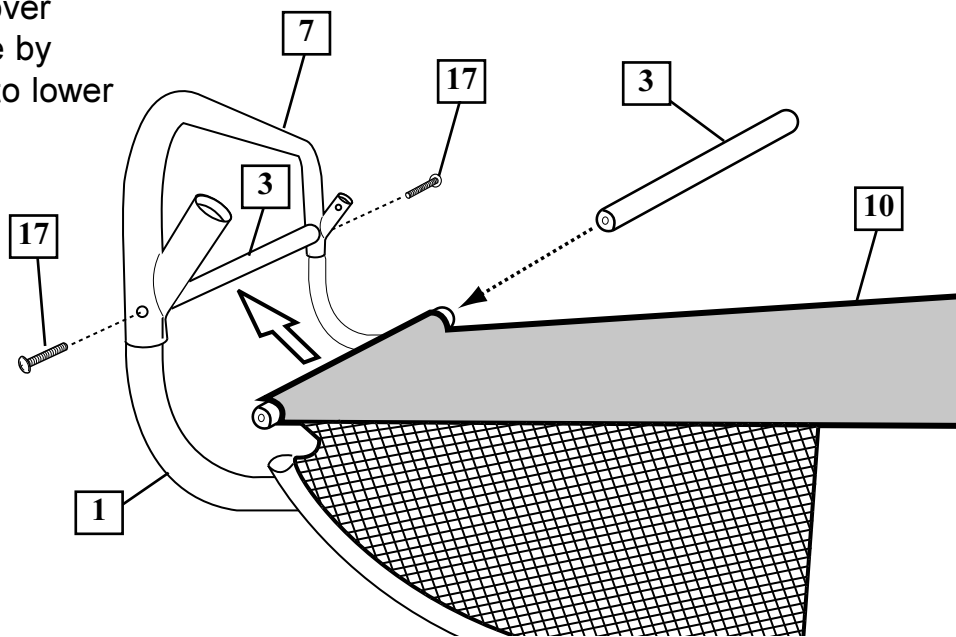

- 3.** Slide curved support pipe (2) over curved support pipe (1)
NOTE: Locking pins on curved support pipe (2) MUST be facing inward (toward each other).

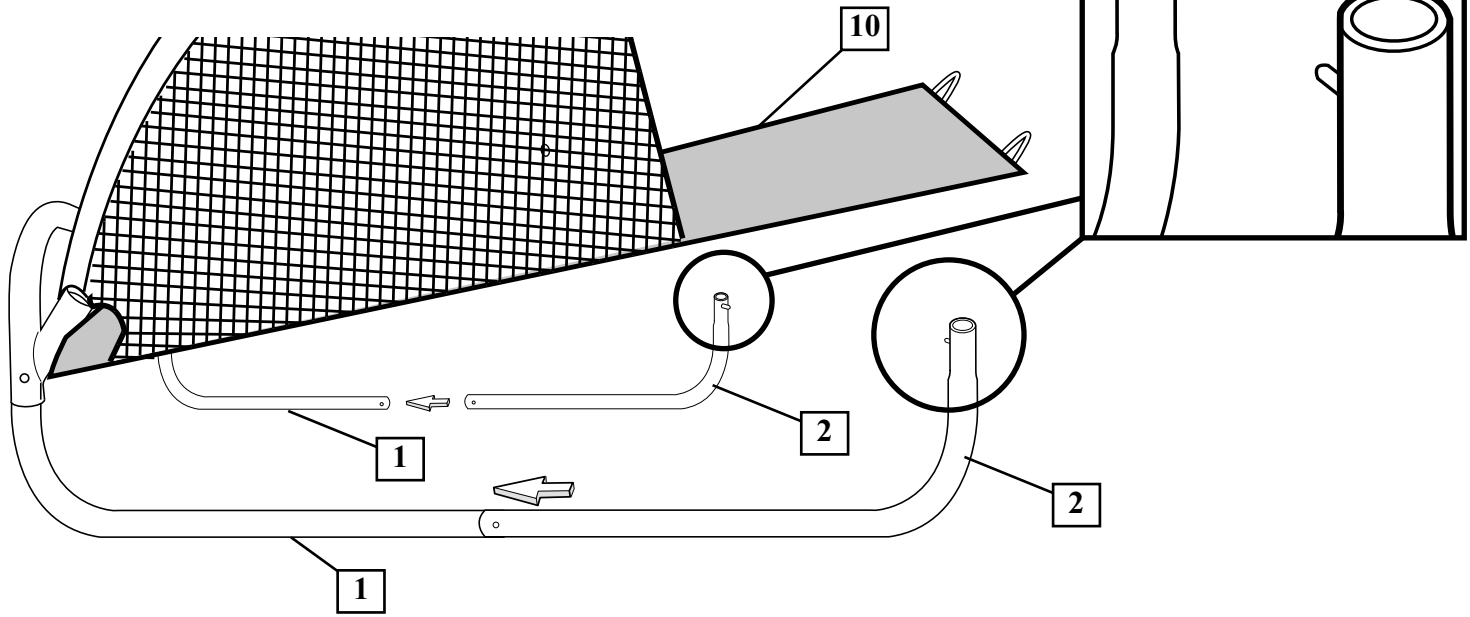

- 4.** Connect threaded stabilizer pipe (3) using screws (17).

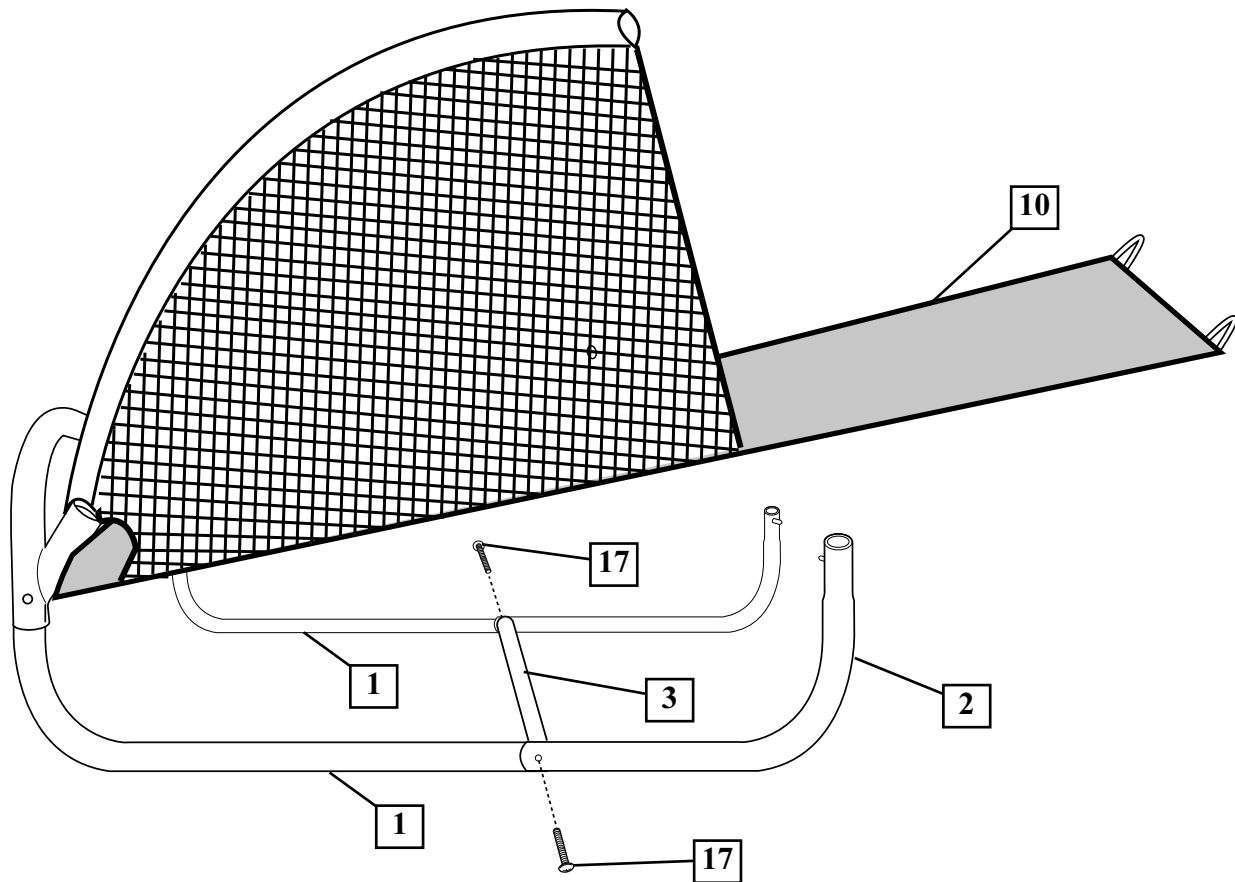

- 5.** Attach straight bars (5) by snapping them over the pins of curved support pipes (2).

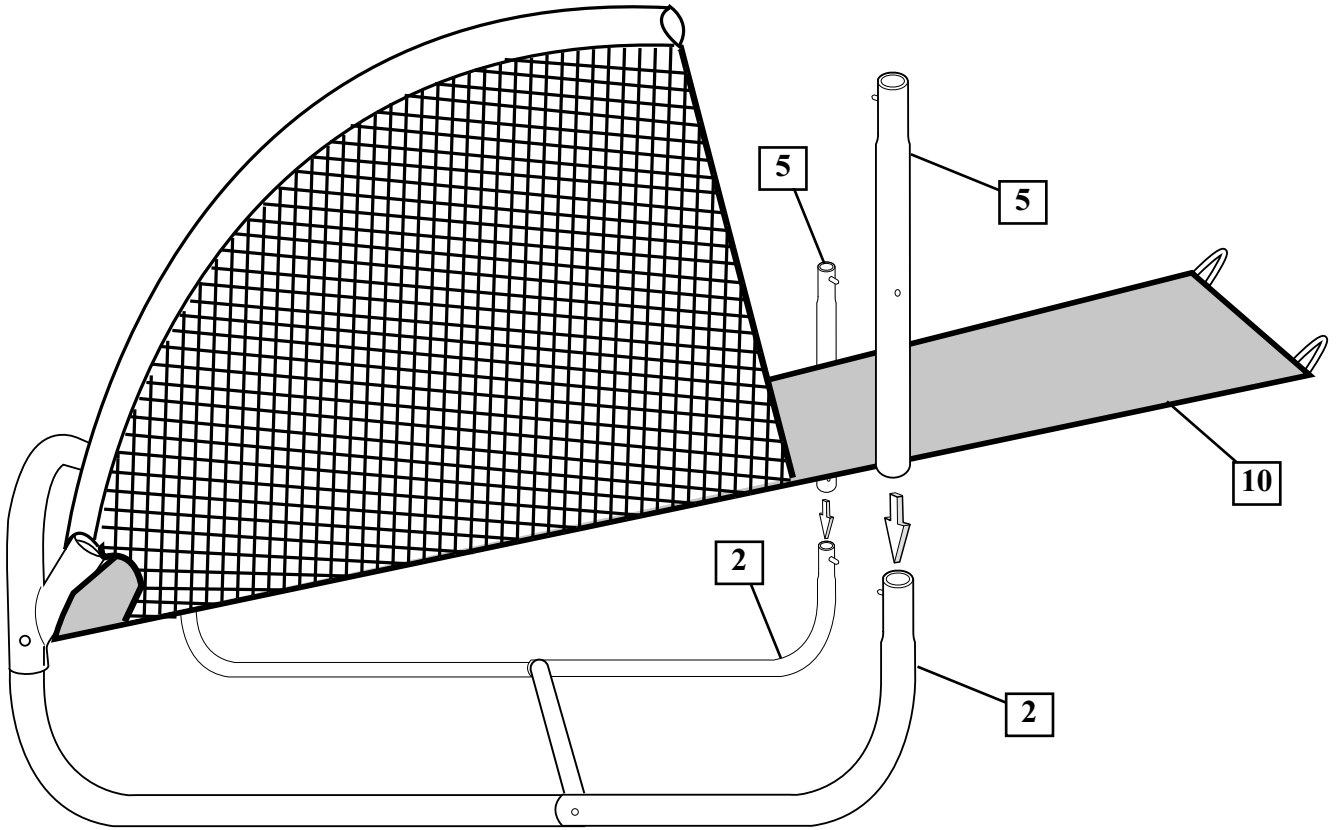

- 6.** Connect threaded stabilizer pipe (3) using screws (17).

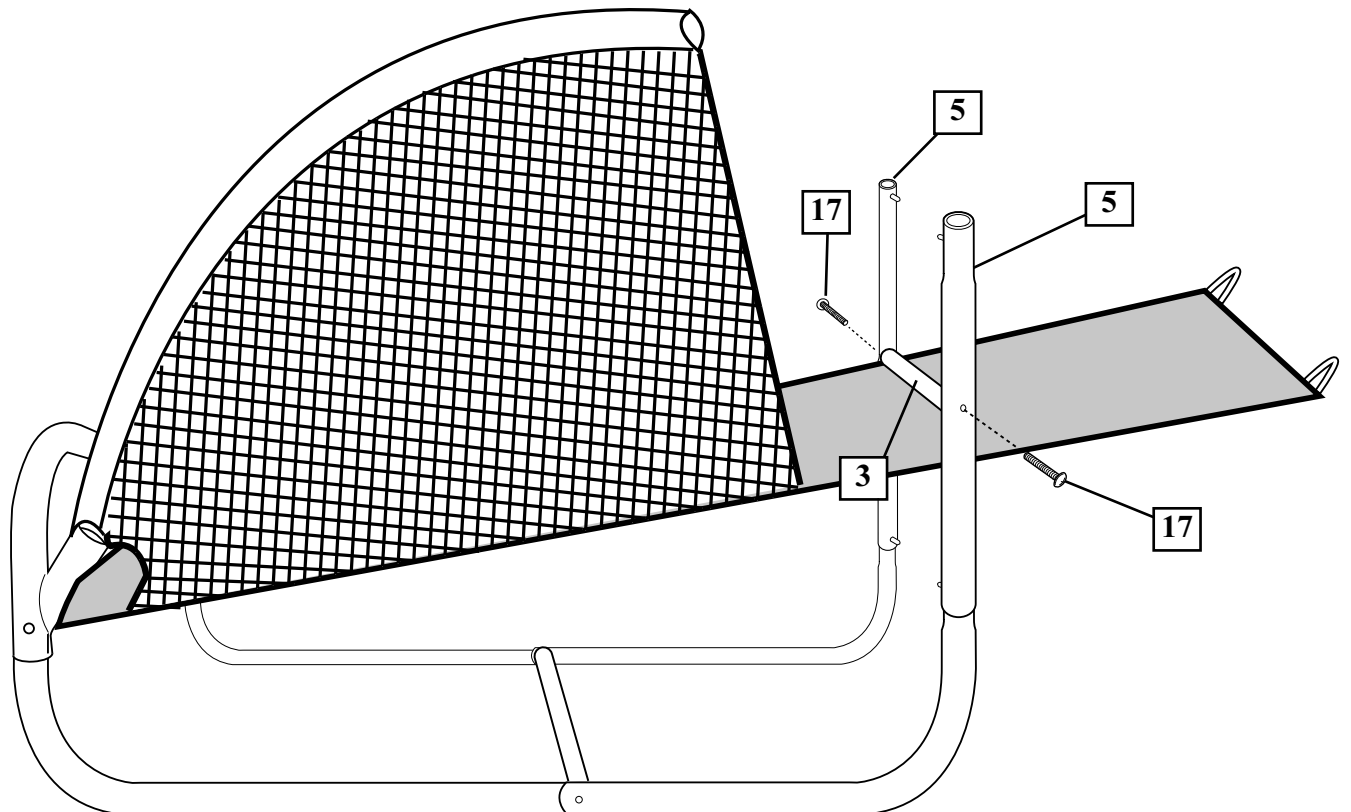

- 7.** Slide upper U-pipe (6) over straight pipes (5).
NOTE: Locking pins on pipe (5) MUST snap into holes of upper U-pipe (6). See FIG. A.

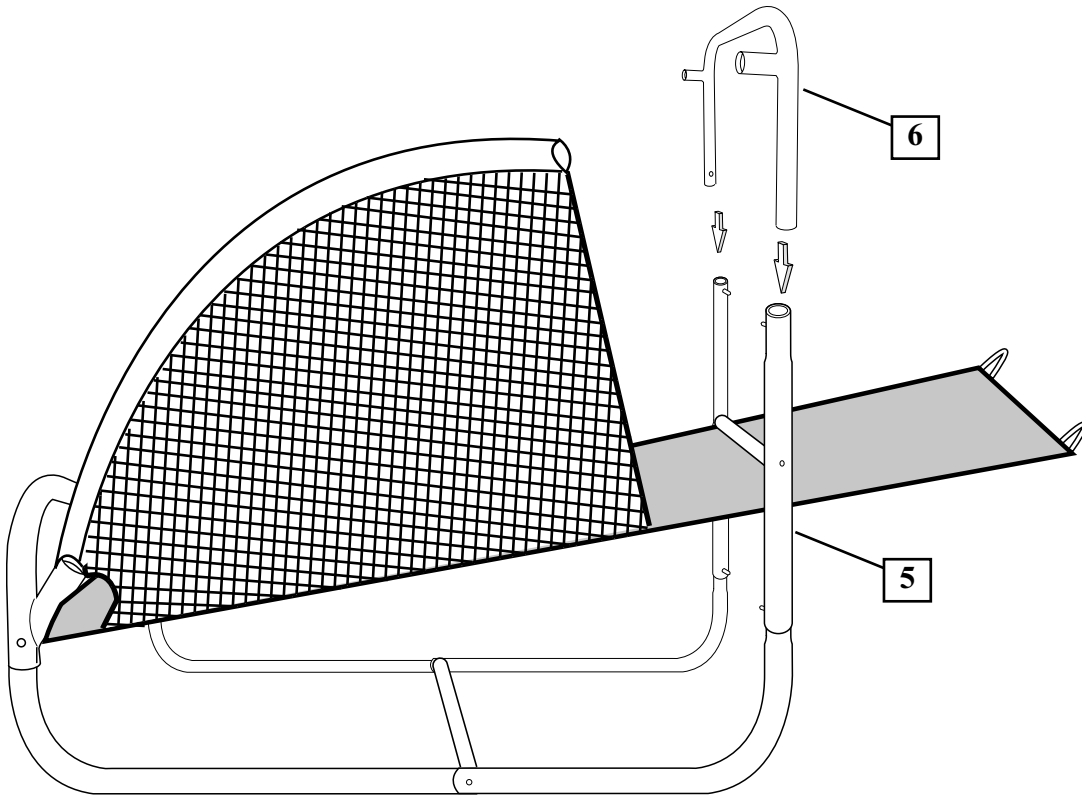
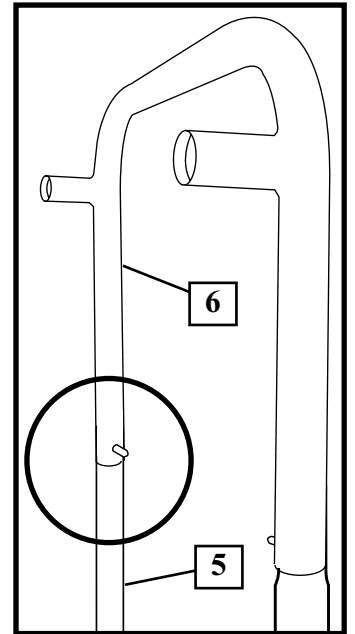
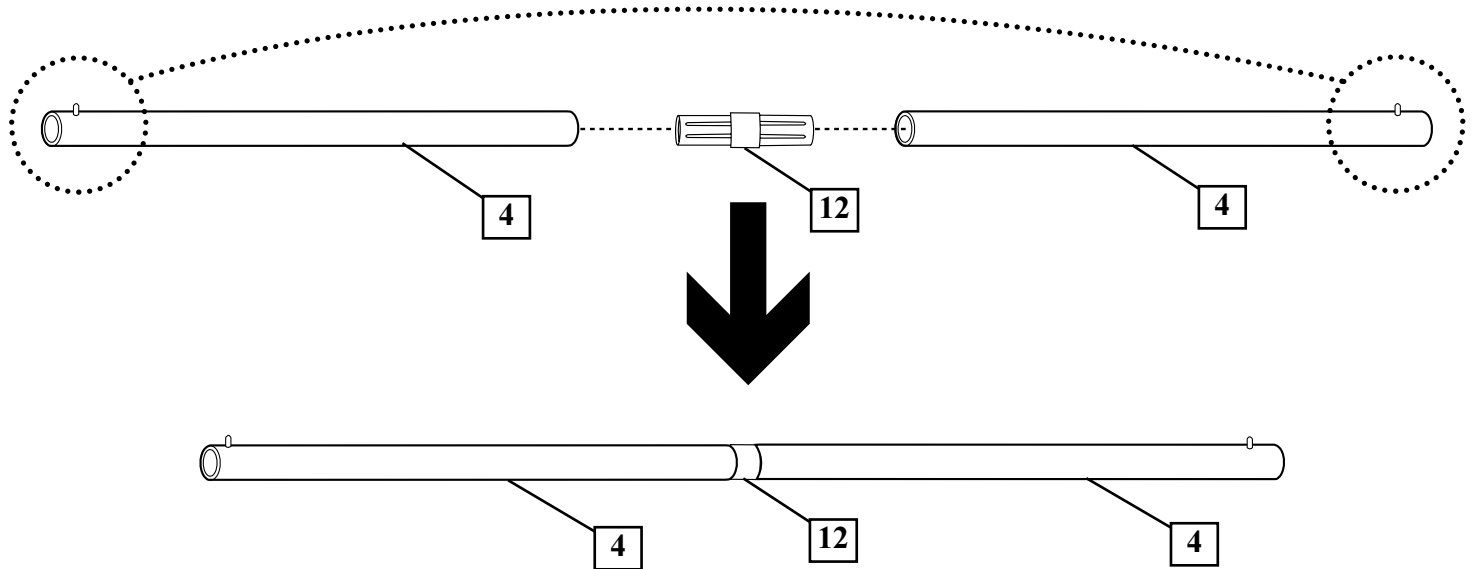

FIG. A.



- 8.** Connect white, plastic pipes (4) together with plastic adapter (12).
NOTE: Keep pins of each pipe aligned.



- 9.** Slide white pipe assembly through sleeve of tarp (10) and snap it into opening on lower U-pipe (7). See **FIG. A.**

NOTE: Locking pins on pipe (4) **MUST** snap into holes of U-pipe (7).

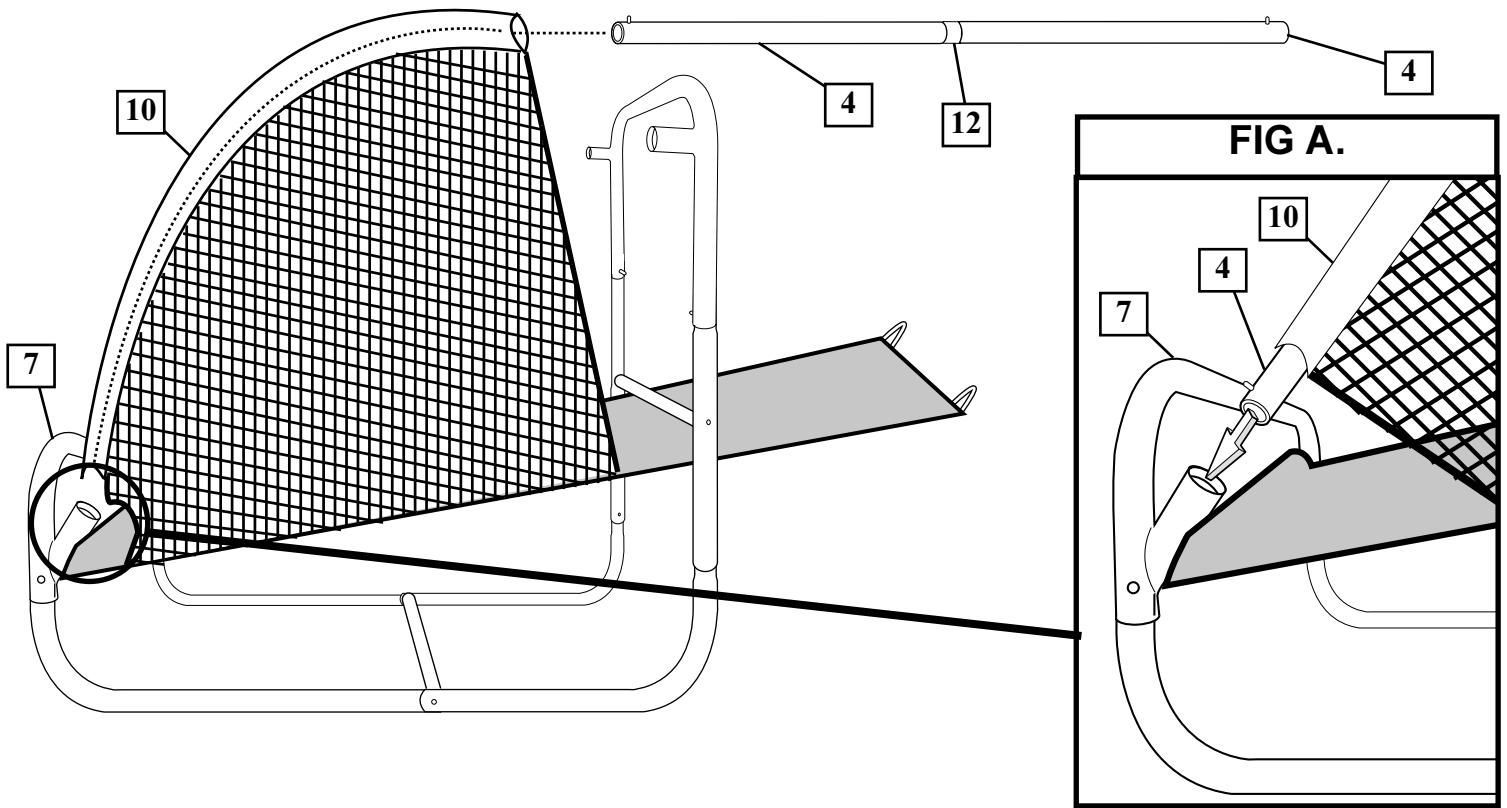

- 10.** Snap white pipe assembly into opening in upper U-pipe (6).

NOTE: Locking pins on white pipe (4) **MUST** snap into holes of upper U-pipe (6).

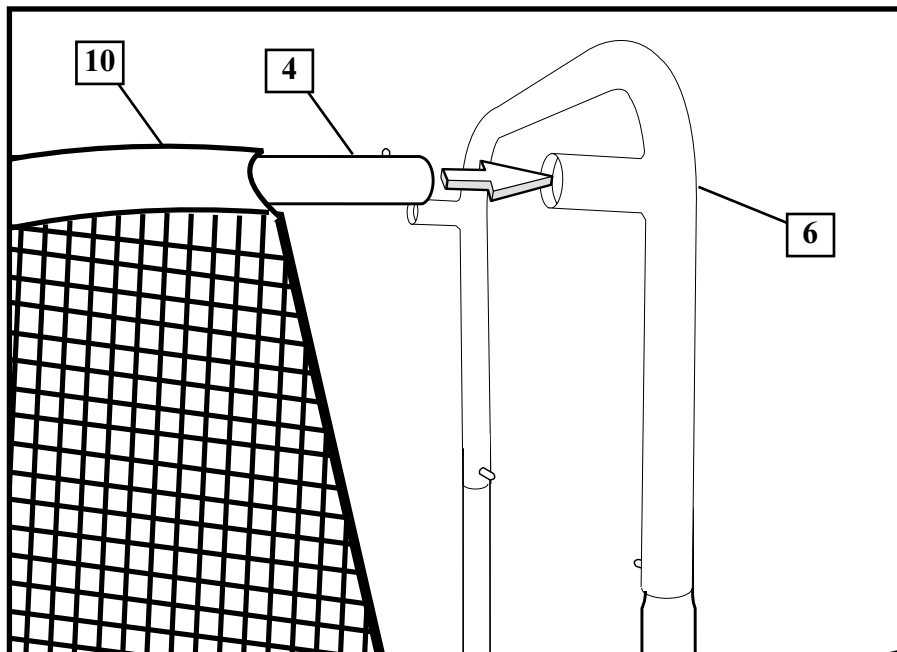

SECTION B: ASSEMBLE THE BOARD AND RIM

TOOLS REQUIRED FOR THIS SECTION

Phillips-Head Screwdriver

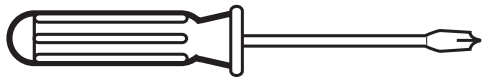

HARDWARE USED IN THIS SECTION (actual size)



Item #16 (2)

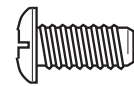

Item #18 (4)



Item #13 (2)

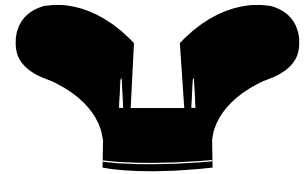

Item #15 (2)

11. Install net (8) to rim (9).

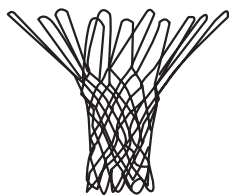

Item #8 (1)

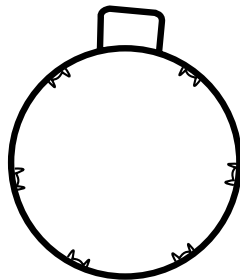

Item #9 (1)

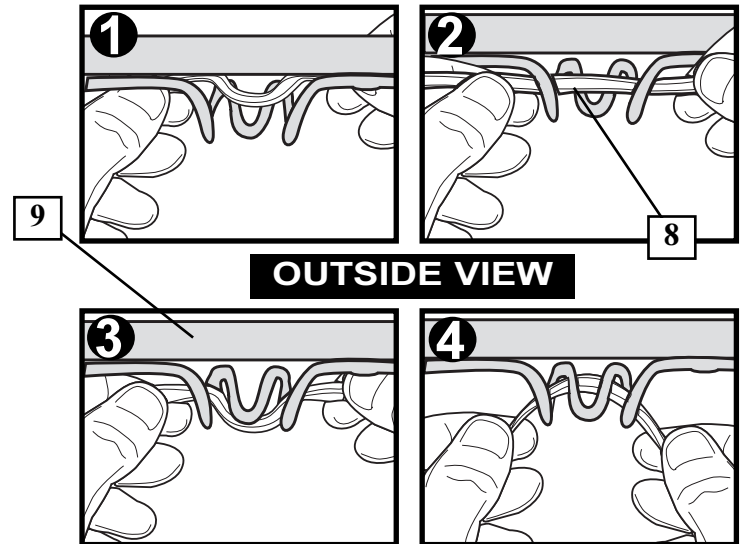

OUTSIDE VIEW

12. Position rim bracket (11) inside welded bracket extending from ring of the rim (9).

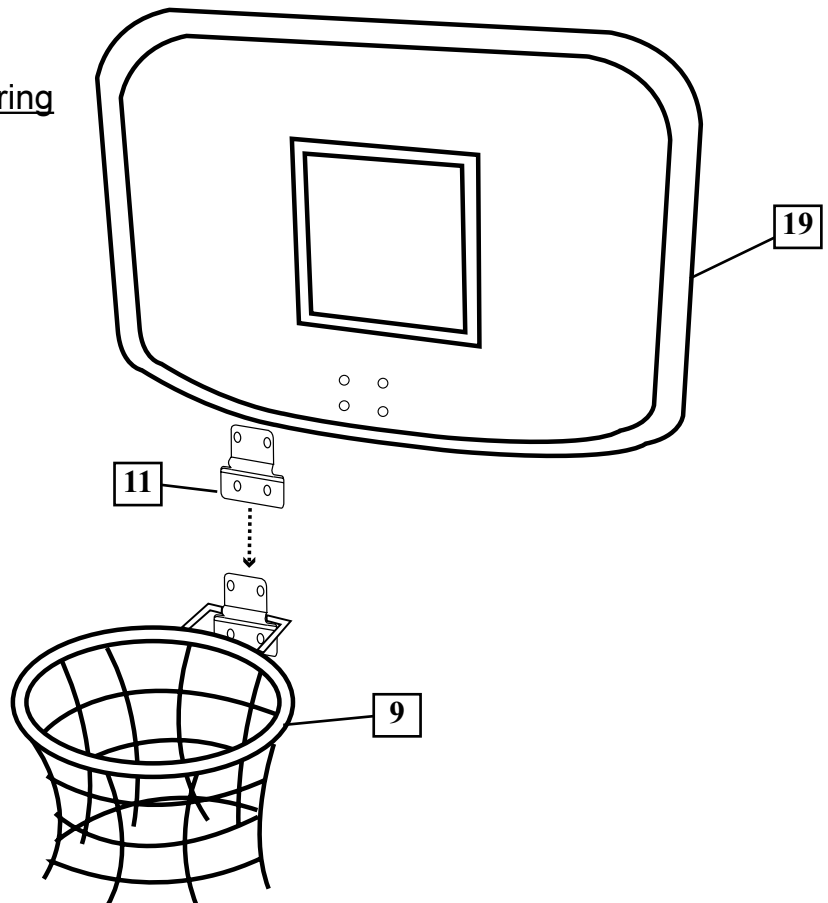
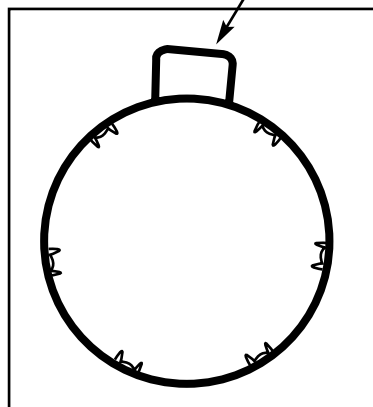

13. Attach rim (9) to board (19) using screws (18), rim bracket (11) and threaded reinforcement brackets (14).

NOTE: Rim should be able to flip up. If it flops down the rim bracket (11) is on upside down.

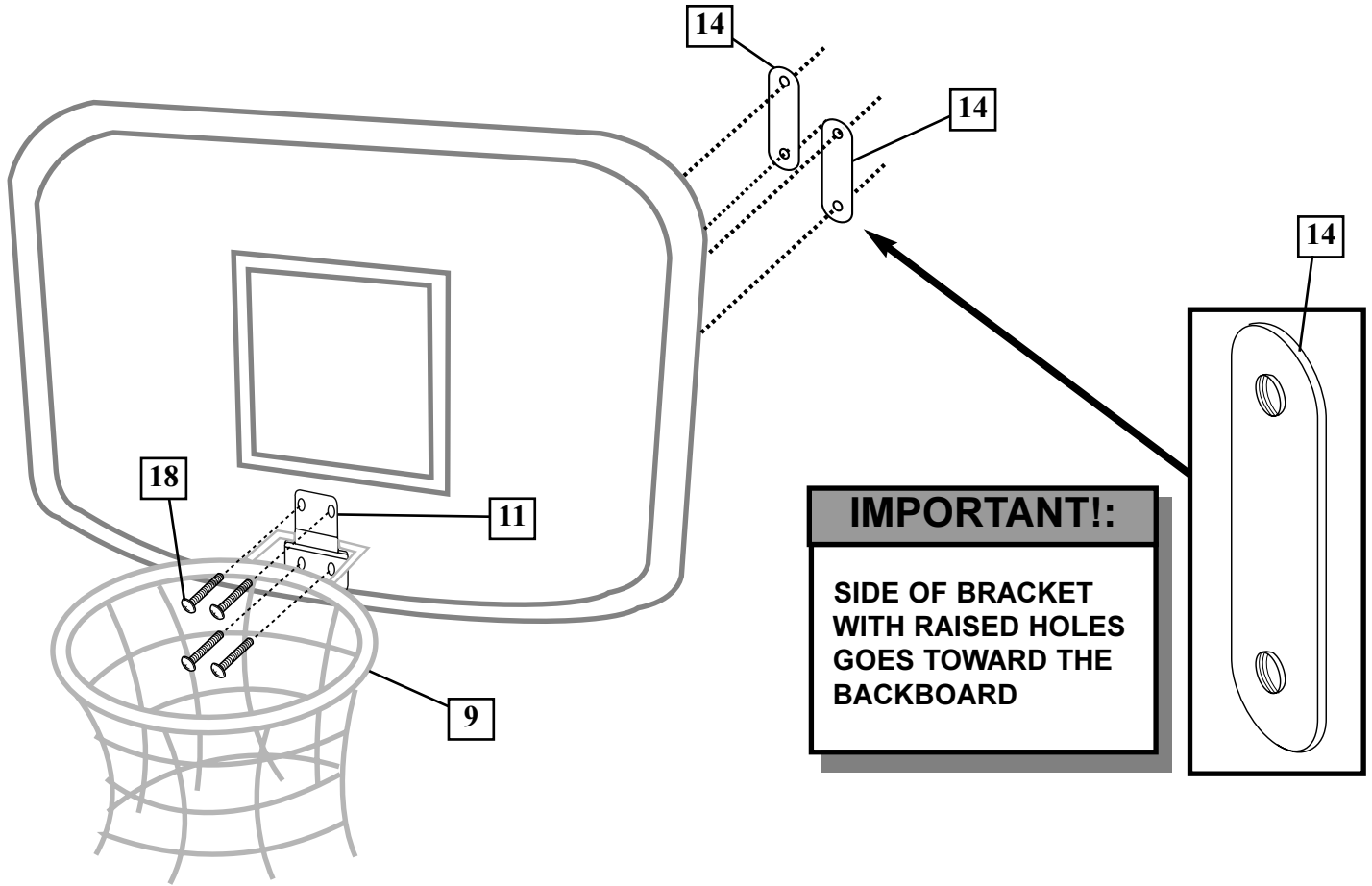

14. Hook board and rim assembly onto extension pipes of upper U-pipe (6).

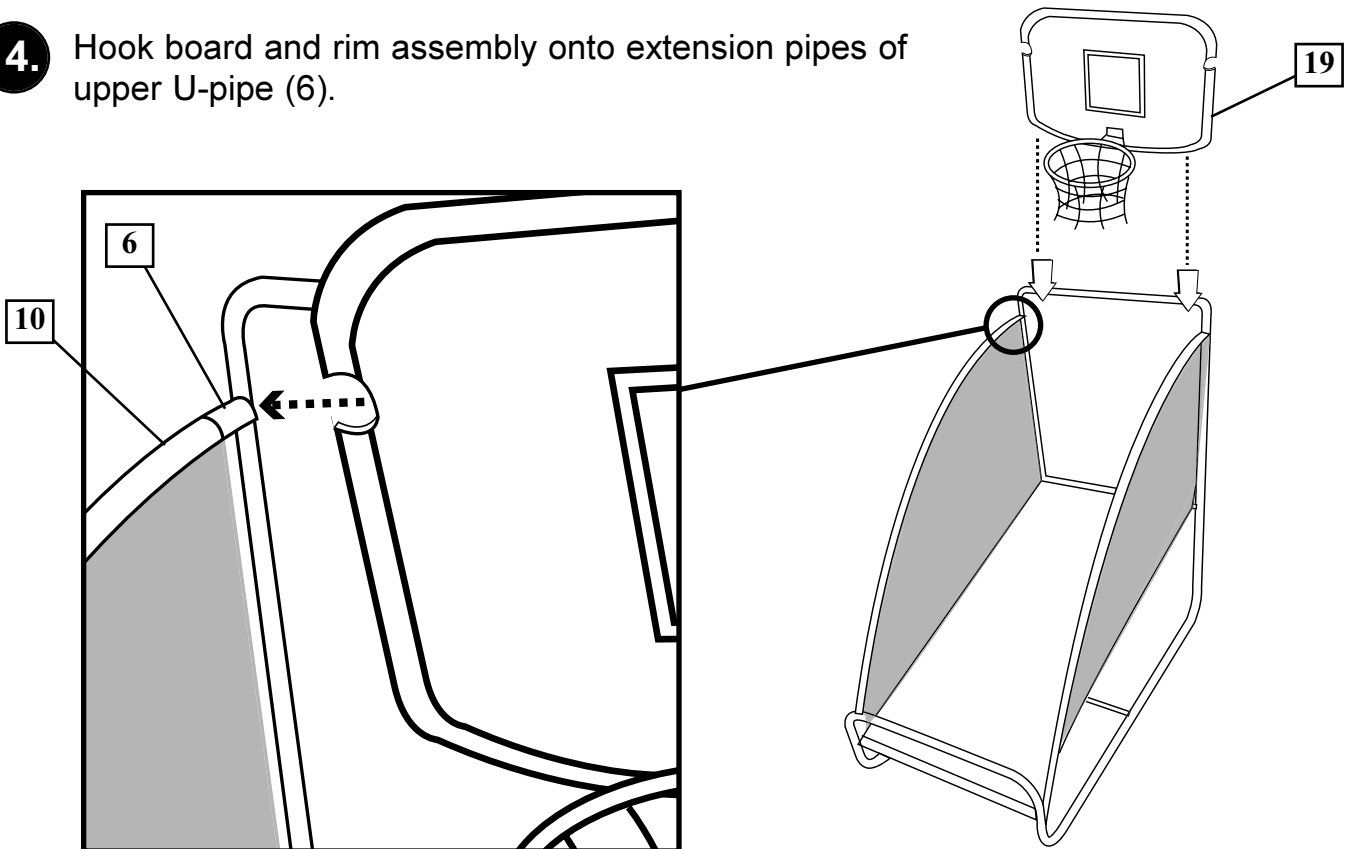

- 15.** Secure board (19) with screws (16), bracket (21), washer (13) and wingnuts (15). Loop tarp onto hook of bracket (21) as shown.

NOTE:
Brackets (21) do not attach to the tubes. They are positioned correctly when attached to the board.

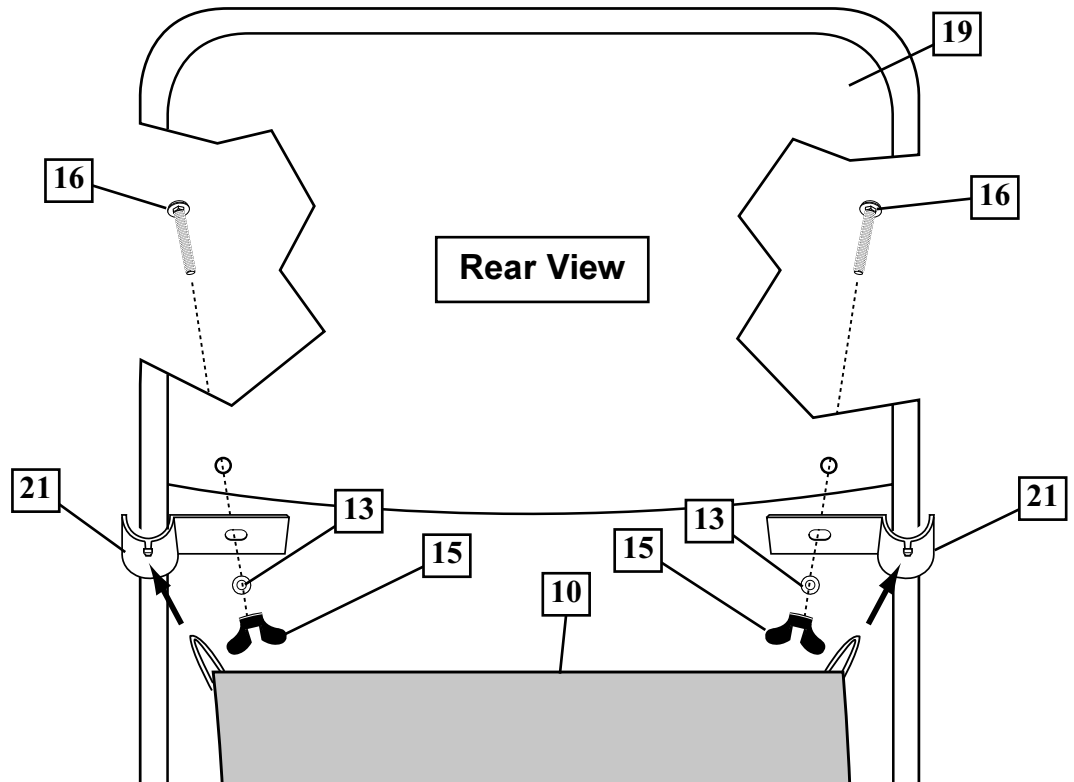

- 16.** Inflate mini basketballs (20) and place on tarp.

